

FIRST READING

See, I am doing something new.
Isaiah 43: 18-19, 21-22, 24-25

PSALM

Because of my integrity You sustain me.
Psalms 41

SECOND READING

He has also put His seal upon us and given
the Spirit in our hearts.
2 Corinthians 1: 18-22

GOSPEL

Jesus immediately knew in His mind what
they were thinking to themselves.
Mark 2: 1-12



THE SEVENTH SUNDAY OF ORDINARY TIME

22 FEBRUARY 2009

That you may know that the Son of Man
has authority to forgive sins on earth.

Mark 2: 10

CALENDAR

SCHEDULE OF MASSES AND INTENTIONS WEEK OF 22-28 FEB

| | | |
|------------|-----------------|--|
| SAT | 05:00 PM | Priest's intentions |
| SUN | Masses | Priest's intentions |
| MON | 07:30 AM | Benefactors of the parish |
| | 05:30 PM | The Simonds family |
| TUE | 07:30 AM | Emma Cinibulk |
| | 05:30 PM | † Miriam and Rolly Somer; † Tom Del Sarto |
| WED | 07:30 AM | The Oliver family |
| | 05:30 PM | Kathleen Boldrick |
| | 07:30 PM | † Clifford Ryan |
| THU | 07:30 AM | † Fr. Edward V. Warren, S.J. |
| | 12:00 PM | † Ruth Shrader |
| | 05:30 PM | † Tony "TJ" Gonzales |
| FRI | 07:30 AM | Sylvia Sands |
| | 05:30 PM | † Olga Silvestri |
| SAT | 08:00 AM | † Shirley Fennell |

MEETINGS AND SPECIAL EVENTS

| | | |
|----------------|--------------------|---|
| MON-FRI | 07:10 AM | Morning Prayer |
| MON-FRI | 05:10 PM | Evening Prayer |
| SAT | 07:40 AM | Morning Prayer |
| 22 FEB | (Sunday) | |
| | 07:30 PM | Holy Hour |
| 23 FEB | (Monday) | |
| | 09:00 AM | Bible Group |
| | 07:30 PM | Legion of Mary |
| | 07:30 PM | RCIA |
| | 07:30 PM | St. Vincent de Paul Society |
| 24 FEB | (Tuesday) | |
| | 06:00 PM | Cenacles of Life Rosary |
| 25 FEB | (Wednesday) | Ash Wednesday  |
| 26 FEB | (Thursday) | |
| | 11:00 AM | The Thursday Group |
| | 06:00 PM | Perpetual Help Novena |
| 27 FEB | (Friday) | |
| | 06:00 PM | Stations of the Cross  |
| 28 FEB | (Saturday) | |
| | 08:00 AM | Lenten Retreat |
| | 10:00 AM - | Confessions |
| | 12:00 PM | (Opus Dei priest) |
| | 03:30 PM - | Confessions |
| | 04:30 PM | (parish priest) |



NATIVITY PARISH CAPITAL CAMPAIGN PHASE I

MULTI-PURPOSE PAVILION AND KINDERGARTEN

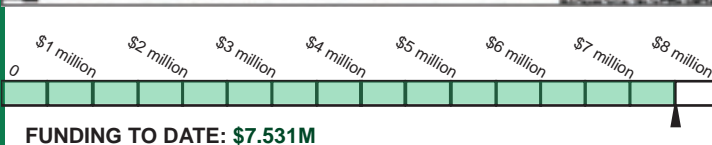

STATIONS OF THE CROSS

We will have **Stations of the Cross** every **Friday** during **Lent**, following the **05:30 PM** Mass. Please join us.



PARISH OFFERINGS

WEEKEND OF
07-08 FEB

TOTAL: \$ **9,871**

SAINTS AND OBSERVANCES

SOLEMNITY, FEAST, MEMORIAL • OPTIONAL MEMORIAL • OTHER

22 FEB (Saturday): WASHINGTON'S BIRTHDAY

"It is impossible to rightly govern a nation without God and the Bible."



25 FEB (Wednesday): ASH WEDNESDAY

Lent begins this week, on **Wednesday, 25 February 2009**, with **Ash Wednesday**. It is a day of fast (ages 18 to 60) and abstinence from meat (ages 14 up). Masses that day will be at **07:30 AM, 05:30 PM and 07:30 PM**. Ashes will be distributed after Mass.

STATIONS OF THE CROSS

We will have **Stations of the Cross** every **Friday** during **Lent**, following the **05:30 PM** Mass. Please join us.

23 FEB (Monday): SAINT POLYCARP, Bishop and Martyr (d. 155)

Bishop of Smyrna, Polycarp was loved and revered by his flock. We know that he accompanied **St. Ignatius of Antioch** to Rome to confer with **Pope Anicetus** concerning the celebration of Easter. He was martyred by a dagger after unsuccessful attempts that he be burned at the stake in the amphitheater at Smyrna.

FAST AND ABSTINENCE

The observance of a **fast** is to take only a single full meal during the course of the day, typically after **03:00 PM**. To maintain strength, one or two smaller meals may also be taken, if together they do not equal another full meal. The fast binds on all those ages 18-60.

The observance of **abstinence** is to refrain from eating any meat. Abstinence binds on all those ages 14 and older.

Ash Wednesday and **Good Friday** are days of both **fast and abstinence**. It is recommended that **all Fridays in Lent** be observed as days of **abstinence**.

MINISTRY AND GROUP NEWS

ROSARY FOR LIFE

Please join us for saying the Rosary outside a nearby abortion clinic, **First Saturday, 07 March 2009**. We meet between the O'Hare Center and the Church after the 08:00 AM Mass on Saturday before heading over. Please contact **Eileen** at **650/799-4722** for more information.

SHARE YOUR TALENTS - 09:30 MUSIC GROUP

The **09:30 music group** is always looking for more singers and musicians. If you like to sing or play an instrument: flute, guitar, bass, horns, sax, strings - you name it - consider being a part of this fun ministry! Teenagers welcome. Rehearsals are **08:30 AM Sunday** before Mass in the **O'Hare Center**. Interested? Contact **Barbara Nelson** at **650/839-1010** or **bnelson1015@gmail.com**. Or just see one of us after the 09:30 AM Mass on Sundays.



NATIVITY MOMS GROUP

All mothers are invited to join us for prayer and fellowship on **Friday, 06 March 2009** from **10:30 AM** until **12:00 PM** in the **O'Hare Center**. Please bring your little ones with you! Contact **Christine Semler** at **650/594-4637** for more information.

EUCCHARISTIC ADORATION

Please come to visit our Lord during the week, as the church is open 24x7 and He awaits you. Also, everyone is encouraged to sign up for one hour. This will ensure your weekly meeting with Jesus. You may sign up for any hour. Please consider the following hours which currently have no one assigned:

FRI: 01:00 AM - 03:00 AM (1st Friday of each month)

Please call **650/322-3013** for more information or to sign up.



NATIVITY DAYS IN 40 DAYS FOR LIFE

During Lent, Nativity will schedule people for a prayer vigil on **Saturday, 14 March 2009** and **Wednesday, 25 March 2009**, the Feast of the Annunciation, as part of the nationwide **40 Days for Life** effort praying for an end to abortion. The prayer vigil will occur on public property near an abortion clinic in San Mateo between **07:00 AM - 07:00 PM**. There will be a minimum of 2 people per hour. Please call **Eileen** at **650/799-4722** to sign up for hourly time slots and more information.

GOOD FOOD AND GOOD MUSIC!

Join us for the **Nativity Parish 2009 Crab Cioppino Feast**. In addition to the best crab cioppino anywhere you will be treated to the warm tenor voice of **Pasquale Esposito**, a very popular local Italian singer of both contemporary and classical music. You can learn more about Pasquale at **www.pasqualesposito.com**. Tickets are on sale for Nativity's Crab Cioppino Dinner on **14 March 2009** at the Sobrato Pavilion at Nativity School. The dinner will include Dungeness Crab Cioppino with clams and shrimp, hearts of romaine salad; sourdough bread, and biscotti and sorbet. Wine and beer will be available. The tickets are \$40.00 per person and include 2 drink tickets per adult. The tickets are \$40.00 per person and include 2 drink tickets per adult. Reservation forms are available at the entrance to the church or you may see one of the men outside church today. If you have any questions please contact **Paul Hernandez** at **650/670-7513** or **paulh@pro-bel.ca**.

Pregnant? Need Help? Please contact First Resort (650/261-9115), the Juan Diego Society (408/258-2008) or the Gabriel Project (800/910-0191).

ANNOUNCEMENTS

OUR PARISH FAMILY

Please welcome the newest members of our Christian community:



- **Trae Elsa** daughter of **Timothy** and **Laura Poole**

May this family grow in holiness daily in response to their baptismal calling.

ONE DAY PARISH LENTEN RETREAT

Repeating a favorite from two years ago, Nativity Parish will again present a one-day parish lenten retreat on **Saturday, 28 February 2009** (the Saturday following **Ash Wednesday**). This retreat is placed at the beginning of Lent to encourage a deeper participation in that liturgical season. As was done previously, the day will begin with morning Mass at 08:00 AM, a small breakfast (coffee, donuts, and fruit), and then a mixture of conferences, prayer, and silent reflection until 03:00 PM when there will be Benediction and the Chaplet of Divine Mercy. It will conclude at 03:30 PM. Confessions will be available at certain times of the day. **Monsignor Otellini** and **Deacon Peloso** will share the conferences, each giving two. The general theme will be St. Paul (as this is the year of St. Paul) on topics of conversion, mission, and penance. Orders for lunch will be taken at the breakfast. Please plan to attend. There will be flyers available with the schedule. For questions, call **Deacon Dominick Peloso** at **650/269-6279**.

LENTEN TALKS ON ST. PAUL

Dr. Ruth Ohm will be speaking at Nativity on the first five Tuesdays of Lent in the **O'Hare Center** beginning at 07:30 PM (**03 through 31 March 2009**). Dr. Ohm teaches New Testament at St. Patrick's Seminary and University. Her special interests include Pauline material, Christian period archaeology in the Greek East with a focus on the ancient city of Ephesus, and ancient Byzantine Rite liturgy. For over 10 years she has collaborated with the Director of Christian period excavations in Ephesus, Dr. Renate Pillinger (University of Vienna). She speaks and publishes on Ephesus' ancient chapels and the so-called Cave of St. Paul. This series of five presentations on **St. Paul** will focus on some aspects of the apostle's practiced spirituality. We will examine how St. Paul communicates to the early Christian communities a cross-centered spirituality, the impact of the covenant, the gospel message, and the responsibility of evangelization.

ASH WEDNESDAY

Lent begins this week, on **Wednesday, 25 February 2009**, with **Ash Wednesday**. It is a day of fast (ages 18 to 60) and abstinence from meat (ages 14 up). Masses that day will be at **07:30 AM, 05:30 PM** and **07:30 PM**. Ashes will be distributed after Mass.

IN THE COMMUNITY

ENSORSHIP OF CATHOLIC RADIO?

FCC rule changes currently being developed internally could result in the direct censorship of Catholic radio stations.

Read more at

catholicradioassociation.org/localism.htm.

CATHOLIC RADIO PLEDGE DRIVE

Immaculate Heart Radio's On-Air Pledge Drive will be held **Tuesday, 10 March 2009** through **Thursday, 12 March 2009** -- from **06:00 AM-06:00 PM** daily at Immaculate Heart Radio's Live Studio located at **Mater Dolorosa School** in **South San Francisco**. Please join the Immaculate Heart Radio Staff at our upcoming Pledge Drive. Meet Catholic Radio Personalities, be interviewed live on the radio, pray the Rosary with our staff, participate in Adoration, enjoy fellowship with Catholics in your area, talk with listeners and witness their testimonies, and experience the joy and peace that comes from sharing your Catholic Faith. Refreshments served all day. Free Giveaways!!

Spaces are limited -Sign-up for any time during the Pledge Drive. Call **Debora Heinrichs** at **866/774-3278 x221** or email her at dheinrichs@ihradio.org.

Visit our website at www.ihradio.org.

ONE MILLION ROSARIES FOR UNBORN BABIES

Join a nationwide prayer event this May, praying one million rosaries for an end to the killing of the unborn. Information at saintmichaelthearchangelorganization.org.

ST. PATRICK'S DAY LUNCHEON

The **Hibernian Newman Club's 45th Annual St. Patrick Day Luncheon** will be held **Tuesday, 17 March 2009** at the Hilton San Francisco Hotel. 11:00 AM: No-Host Reception, 12:00 PM: Corned Beef & Cabbage. Traditional Irish music and entertainment, benefiting the Catholic College Campus Ministry programs for the Archdiocese of San Francisco. Tickets are **\$80**. For more information and tickets, call **415/386-3434**.

AT VALLOMBROSA RETREAT CENTER

Start a new Lenten practice! Come to begin your **Wednesday** mornings with quiet contemplative prayer. Gather in our beautiful chapel for an hour of gentle music, scripture and silent reflection, followed by an optional continental breakfast. Prayer will be led by **Sister Ingrid Clemmensen, OP**, Program Director at Vallombrosa Retreat Center.

Wednesdays during Lent, **07:30-08:30 AM**.

25 February - 04, 11, 18, 25 March - 01, 08 April 2009.

VOCATION RETREAT FOR YOUNG WOMEN

On **Sunday, 29 March 2009** the **Sisters of Nazareth** will be having a vocation retreat for young women from **09:00 AM-04:00 PM** at Nazareth House, 245 Nova Albion Way, San Rafael, California. For more information call **Sr. Margaret Clare** at **415/479-8282** or **Sr. Fintan** at **310/216-8170**.

You are never too far gone for the Father's forgiveness and grace.



Message of His Holiness Pope Benedict XVI
for **LENT 2009**

THE HOLY FATHER'S PRAYER INTENTIONS

Each month **His Holiness Benedict XVI** asks for general and missionary prayer intentions.

For **February 2009**, the Holy Father's prayer intentions are:

General: That the Pastors of the Church may always be docile to the action of the Holy Spirit in their teaching and in their service to God's people.

Missionary: That the Church in Africa may find adequate ways and means to promote reconciliation, justice and peace efficaciously, according to the indications of the Synod of the Bishops' Special Assembly for Africa.



The practice of fasting is very present in the first Christian community (cf. Acts 13,3; 14,22; 27,21; 2 Cor 6,5). The Church Fathers, too, speak of the force of fasting to bridle sin, especially the lusts of the "old Adam," and open in the heart of the believer a path to God. Moreover, fasting is a practice that is encountered frequently and recommended by the saints of every age. Saint Peter Chrysologus writes: "Fasting is the soul of prayer, mercy is the lifeblood of fasting. So if you pray, fast; if you fast, show mercy; if you want your petition to be heard, hear the petition of others. If you do not close your ear to others, you open God's ear to yourself" (Sermo 43: PL 52, 320. 322).

In our own day, fasting seems to have lost something of its spiritual meaning, and has taken on, in a culture characterized by the search for material well-being, a therapeutic value for the care of one's body. Fasting certainly brings benefits to physical well-being, but for believers, it is, in the first place, a "therapy" to heal all that prevents them from conformity to the will of God. In the Apostolic Constitution *Pænitentini* of 1966, the Servant of God Paul VI saw the need to present fasting within the call of every Christian to "no longer live for himself, but for Him who loves him and gave himself for him ... he will also have to live for his brethren" (cf. Ch. I). Lent could be a propitious time to present again the norms contained in the Apostolic Constitution, so that the authentic and perennial significance of this long held practice may be rediscovered, and thus assist us to mortify our egoism and open our heart to love of God and neighbor, the first and greatest Commandment of the new Law and compendium of the entire Gospel (cf. Mt 22, 34-40).

The faithful practice of fasting contributes, moreover, to conferring unity to the whole person, body and soul, helping to avoid sin and grow in intimacy with the Lord. Saint Augustine, who knew all too well his own negative impulses, defining them as "twisted and tangled knottiness" (*Confessions*, II, 10.18), writes: "I will certainly impose privation, but it is so that he will forgive me, to be pleasing in his eyes, that I may enjoy his delightfulness" (Sermo 400, 3, 3: PL 40, 708). Denying material food, which nourishes our body, nurtures an interior disposition to listen to Christ and be fed by His saving word. Through fasting and praying, we allow Him to come and satisfy the deepest hunger that we experience in the depths of our being: the hunger and thirst for God.

At the same time, fasting is an aid to open our eyes to the situation in which so many of our brothers and sisters live. In his First Letter, Saint John admonishes: "If anyone has the world's goods, and sees his brother in need, yet shuts up his bowels of compassion from him – how does the love of God abide in him?" (3,17). Voluntary fasting enables us to grow in the spirit of the Good Samaritan, who bends low and goes to the help of his suffering brother (cf. Encyclical *Deus caritas est*, 15). By freely embracing an act of self-denial for the sake of another, we make a statement that our brother or sister in need is not a stranger. It is precisely to keep alive this welcoming and attentive attitude towards our brothers and sisters that I encourage the parishes and every other community to intensify in Lent the custom of private and communal fasts, joined to the reading of the Word of God, prayer and almsgiving. From the beginning, this has been the hallmark of the Christian community, in which special collections were taken up (cf. 2 Cor 8-9; Rm 15, 25-27), the faithful being invited to give to the poor what had been set aside from their fast (*Didascalia Ap.*, V, 20,18). This practice needs to be rediscovered and encouraged again in our day, especially during the liturgical season of Lent.

(continued next week)

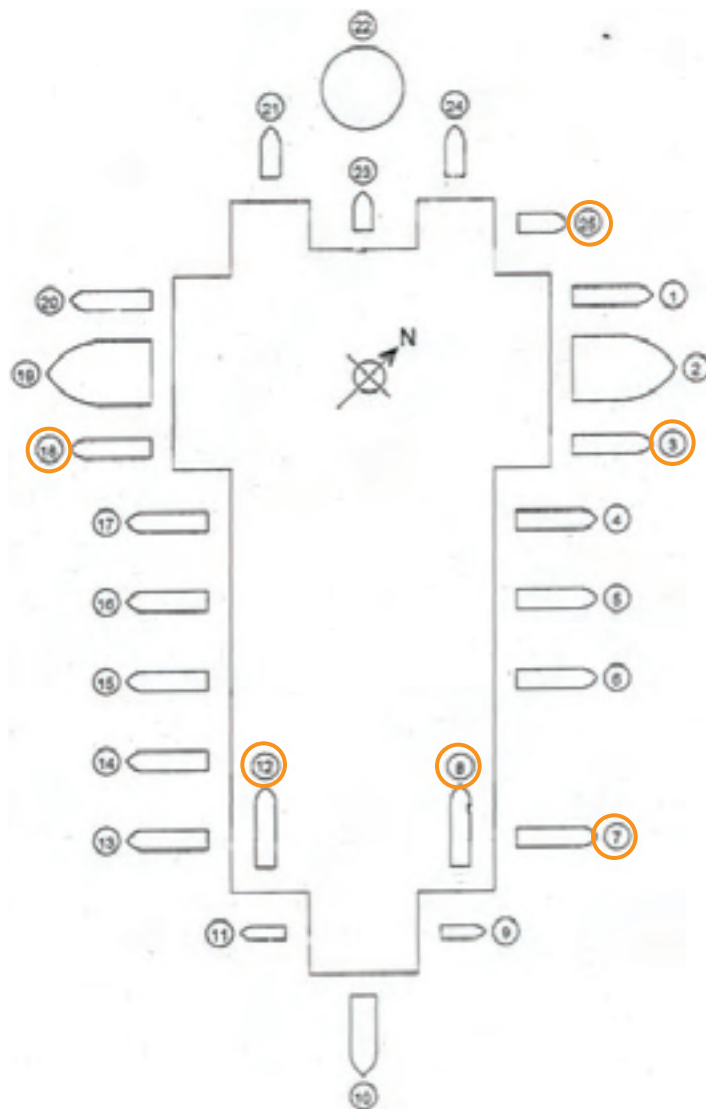

STAINED GLASS WINDOWS UPDATE

The *Rose Window* will be reinstalled, weather permitting, beginning **09 March 2009**. The people at **Hogan Art Glass** have worked very hard to get this beautiful window back to us in less than 2 months. The *Blessed Mother* window should be reinstalled the week of **23 March 2009**. Thanks to the generosity of so many of you, we have been able to move forward with the restoration of the windows much more quickly than we ever imagined. Looking at the above diagram of the church, the following windows are still available: **#3, #7, #8, #12, and #18**, which is **\$6,000.00** to restore; and **#25**, which is **\$2,800.00** to restore. If you are interested in making a financial contribution to this effort in any amount, please contact **Msgr. Otellini, 650/323-7914**.



Thank you to all of you for my 60th anniversary of ordination gift. I had a great time golfing and relaxing in Hawaii, and was able to shoot my age!
 God bless you,
 Fr. Davenport

